

# CILINDRO DE CARRERA CORTA SERIE SSCY



Cilindros compactos adaptados para instalaciones en espacios reducidos:

- ejecución con o sin detección magnética
- simple efecto o doble vástago simple o pasante
- versiones antigiro y con fijaciones incorporadas
- versiones antigiro y con fijaciones incorporadas NBR y POLIURETANO o FKM/FPM
- ejecuciones especiales a petición



ACTUADORES

CILINDRO DE CARRERA CORTA SERIE SSCY

DATOS TÉCNICOS		Polyurethane	NBR		FKM/FPM		Low Temperature				
Presión máxima de funcionamiento	bar	10	10		10		10				
	MPa	1	1		1		1				
Temperatura de funcionamiento	°C	-10 ÷ +80	-10 ÷ +80		-10 ÷ +150 (Cil. no-magnético)		-35 ÷ +80				
Fluido		Aire no lubricado, si utiliza aire lubricado, la lubricación debe ser continua									
Diámetros	mm	12; 16; 20; 25; 32; 40; 50; 63; 80; 100									
Tipo de construcción		A perfilo									
Carrera estándar †	mm	le efecto: de Ø 12 a 25 carrera de 5 a 50									
		de Ø 32 a 40 carrera de 5 a 70									
		de Ø 50 a 63 carrera de 5 a 110									
		de Ø 80 a 100 carrera de 5 a 150									
		Simple efecto: de Ø 12 a 25 carrera de 5 a 25									
		de Ø 32 a 63 carrera de 5 a 50									
		Antirrotación: de Ø 12 a 63 carrera de 5 a 120									
		de Ø 80 a 100 carrera de 5 a 150									
		Vástago pas. hueco: de Ø 20 a 40 carrera de 5 a 100									
		de Ø 50 a 63 carrera de 5 a 130									
		de Ø 80 a 100 carrera de 5 a 165									
		† Carreras máximas aconsejables, valores superiores pueden crear problemas de funcionamiento									
Versiónes		Doble efecto, Simple efecto vástago estirado, Simple efecto vástago retraído, Vástago pasante, Simple efecto vástago pasante, Vástago pasante hueco, Antirrotación, Antirrotación oscilante macho, Antirrotación oscilante hembra, No stick-slip									
Imanes para sensores		Todas las versiones con detección magnética a petición suministrado sin imanes									
Presión de arranque		Ø 12	Ø 16	Ø 20	Ø 25	Ø 32	Ø 40	Ø 50	Ø 63	Ø 80	Ø 100
Vástago simple	bar	0.6	0.6	0.6	0.6	0.6	0.4	0.4	0.4	0.4	0.4
Vástago pasante	bar	1	0.8	0.8	0.8	0.6	0.4	0.4	0.4	0.4	0.4
Fuerza a desarrollar a 6 bar en empuje/rotación		Véanse los "Datos técnicos generales" al comienzo del capítulo									
Pesos		Véanse los "Datos técnicos generales" al comienzo del capítulo									
Notas de uso		Para evitar saltos a velocidades inferiores a 0.2 m/s, utilizar la versión No stick-slip y aire no lubricado									

## COMPONENTES

- 1 VÁSTAGO: acero C45 o inoxidable, cromado en espesor
- 2 CULATA:  
Ø 12 ÷ 25 latón OT 58 niquelado  
Ø 32 ÷ 100 aluminio anodizado
- 3 JUNTAS VÁSTAGO: Poliuretano, NBR o FKM/FPM
- 4 CASQUILLO GUÍA: fleje de acero con revestimiento de bronce y PTFE
- 5 CAMISA: aleación de aluminio perfilado y anodizado
- 6 PISTÓN:  
Ø 12 ÷ 63 resina acetálica  
Ø 80 ÷ 100 en aluminio con patín de guía en PTFE
- 7 JUNTAS PISTÓN: Poliuretano, NBR o FKM/FPM
- 8 MAGNETO: Ø 12 ÷ 25 neodimio - Ø 32 ÷ 100 plastoferrita
- 9 OR estáticos: NBR o FKM/FPM

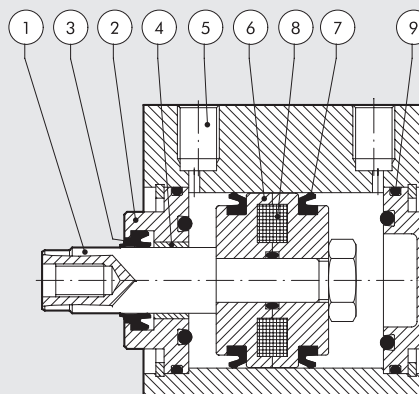

**POSIBILIDAD DE FIJACIÓN**

Fijación directa desde arriba con tornillos largos o con tirantes.  
En este caso se debe utilizar tornillos o tirantes en material de acero inoxidable (ej. AISI 304).

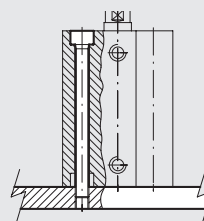

**DIMENSIONES VERSIÓN ESTÁNDAR**

+ = AÑADIR LA CARRERA

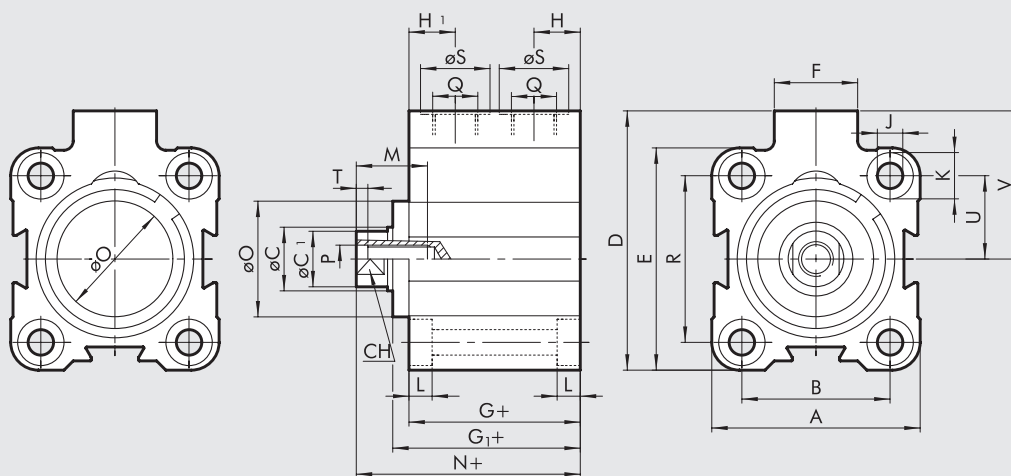
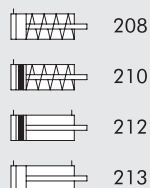

**DIMENSIONES VERSIÓN DOBLE EFECTO ESTÁNDAR**

Ø	A	B	ØC	ØC <sub>1</sub>	D	E	F	G	G <sub>1</sub>	H	H <sub>1</sub>	J	K	L	M	N	ØO	P	Q	R	ØS	CH	T	U	V
12	23.5	13	6	5.5	28	26	11	32.5	-	6.5	10.5	3.7	6	3.7	7	38	-	M3	M5	-	8	5	2	9.5	16.5
16	28	20	8	7.5	33	28	11	33	-	6.7	10.5	3.7	6	3.7	10	37.5	-	M5	M5	20	8	7	2	10	19
20	32	22	10	9	37	32	11	32	-	6.5	10.5	4.6	7.5	4.6	10	37.6	-	M5	M5	22	8	8	2	11	21
25	37	26	10	9	47.5	39	18	33	36.5	8.5	8.5	4.6	7.5	4.6	10	42.5	20	M5	G1/8	28	15	8	2	14	28
32	45	32	12	11	56	48	18	37	40.8	10	10	5.5	10	5.7	15	48.3	25	M6	G1/8	36	15	10	2.5	18	32
40	54.5	40	12	11	62.7	54.5	18	39.5	44.7	10	10	5.5	10	5.7	15	53.2	30	M6	G1/8	40	15	10	2.5	20	35.5
50	66	50	16	15	73	66	18	39.5	46.2	11	11	6.6	11	6.8	18	54.3	35	M8	G1/8	50	15	13	3.5	25	40
63	80	62	16	15	88	80	23	42	48.7	12	12	9	15	9	18	57.7	35	M8	G1/8	62	15	13	3.5	31	48
80	100	82	20	19	110	100	26	57	67.2	14	14	9	15	9	18	75.2	44	M10	G1/4	82	19	17	4	41	60
100	124	103	25	24	134	124	26	64	74.7	15	15	11	18	11	20	84.3	56	M12	G1/4	103	19	22	5	51.5	72

**DIMENSIONES VERSIÓN SIMPLE EFECTO VÁSTAGO RETRAIDO**

Ø	carrera	A	B	ØC	ØC <sub>1</sub>	D	E	F	G	G <sub>1</sub>	H	H <sub>1</sub>	J	K	L	M	N	ØO	P	Q	R	ØS	CH	T	U	V
12	5 ÷ 25	23.5	13	6	5.5	28	26	11	32.5	-	6.5	10.5	3.7	6	3.7	7	38	-	M3	M5	-	8	5	2	9.5	16.5
16	5 ÷ 25	28	20	8	7.5	33	28	11	33	-	6.7	10.5	3.7	6	3.7	10	37.5	-	M5	M5	20	8	7	2	10	19
20	5 ÷ 25	32	22	10	9	37	32	11	32	-	6.5	10.5	4.6	7.5	4.6	10	37.6	-	M5	M5	22	8	8	2	11	21
25	5 ÷ 25	37	26	10	9	47.5	39	18	33	36.5	8.5	8.5	4.6	7.5	4.6	10	42.5	20	M5	G1/8	28	15	8	2	14	28
32	5 ÷ 25	45	32	12	11	56	48	18	37	40.8	10	10	5.5	10	5.7	15	48.3	25	M6	G1/8	36	15	10	2.5	18	32
	> 25 ÷ 50								45	48.8							56.3									
40	5 ÷ 25	54.5	40	12	11	62.7	54.5	18	39.5	44.7	10	10	5.5	10	5.7	15	53.2	30	M6	G1/8	40	15	10	2.5	20	35.5
	> 25 ÷ 50								47.5	52.7							61.2									
50	5 ÷ 25	66	50	16	15	73	66	18	39.5	46.2	11	11	6.6	11	6.8	18	54.3	35	M8	G1/8	50	15	13	3.5	25	40
	> 25 ÷ 50								47.5	54.2							62.3									
63	5 ÷ 25	80	62	16	15	88	80	23	42	48.7	12	12	9	15	9	18	62.3	35	M8	G1/8	62	15	13	3.5	31	48
	> 25 ÷ 50								50	56.7							65.7									



**DIMENSIONES VERSIÓN SIMPLE EFECTO VÁSTAGO EXTENDIDO**

+ = AÑADIR LA CARRERA  
 ++ = AÑADIR 2 VECES LA CARRERA

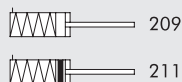
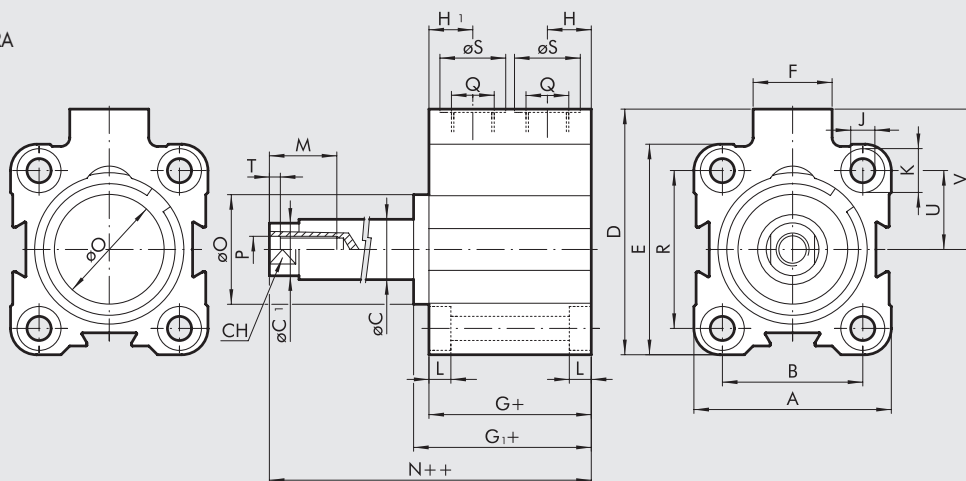

Ø	carrera	A	B	øC	øC <sub>1</sub>	D	E	F	G	G <sub>1</sub>	H	H <sub>1</sub>	J	K	L	M	N	øO	P	Q	R	øS	CH	T	U	V
12	5÷25	23.5	13	6	5.5	28	26	11	32.5	-	6.5	10.5	3.7	6	3.7	7	38	-	M3	M5	-	8	5	2	9.5	16.5
16	5÷25	28	20	8	7.5	33	28	11	33	-	6.7	10.5	3.7	6	3.7	10	37.5	-	M5	M5	20	8	7	2	10	19
20	5÷25	32	22	10	9	37	32	11	32	-	6.5	10.5	4.6	7.5	4.6	10	37.6	-	M5	M5	22	8	8	2	11	21
25	5÷25	37	26	10	9	47.5	39	18	33	36.5	8.5	8.5	4.6	7.5	4.6	10	42.5	20	M5	G1/8	28	15	8	2	14	28
32	5÷25	45	32	12	11	56	48	18	37	40.8	10	10	5.5	10	5.7	15	48.3	25	M6	G1/8	36	15	10	2.5	18	32
	> 25÷50								45	48.8							56.3									
40	5÷25	54.5	40	12	11	62.7	54.5	18	39.5	44.7	10	10	5.5	10	5.7	15	53.2	30	M6	G1/8	40	15	10	2.5	20	35.5
	> 25÷50								47.5	52.7							61.2									
50	5÷25	66	50	16	15	73	66	18	39.5	46.2	11	11	6.6	11	6.8	18	54.3	35	M8	G1/8	50	15	13	3.5	25	40
	> 25÷50								47.5	54.2							62.3									
63	5÷25	80	62	16	15	88	80	23	42	48.7	12	12	9	15	9	18	57.7	35	M8	G1/8	62	15	13	3.5	31	48
	> 25÷50								50	56.7							65.7									

**DIMENSIONES VERSIÓN ANTIRROTACIÓN Ø 12**

+ = AÑADIR LA CARRERA

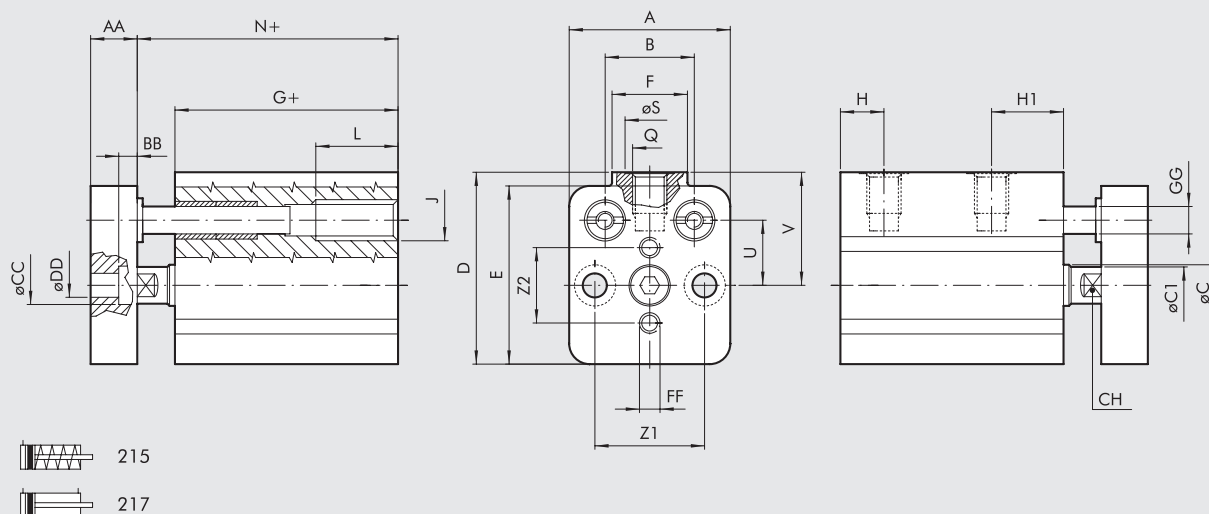

Ø	A	B	øC	øC <sub>1</sub>	D	E	F	G	H	H <sub>1</sub>	J	L	N	Z <sub>1</sub>	Z <sub>2</sub>	Q	øS	CH	U	V	AA	BB	øCC	øDD	FF	øGG
12	23.5	13	6	5.5	28	26	11	32.5	6.5	10.5	M6	12	38	16	11	M5	8	5	9.5	16.5	8	3.5	6	3.5	M3	4

ACTUADORES

CILINDRO DE CARRERA CORTA SERIE SSCY

DIMENSIONES VERSIÓN ANTIRROTACIÓN Ø 16 ÷ 100

+ = AÑADIR LA CARRERA

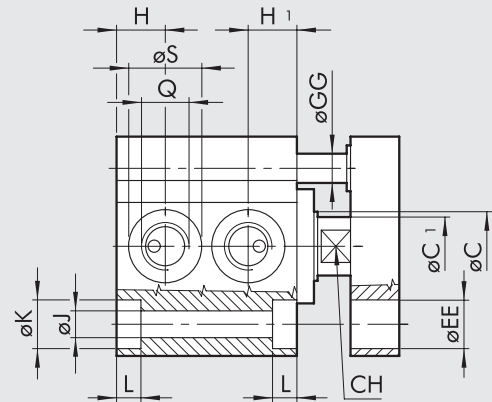
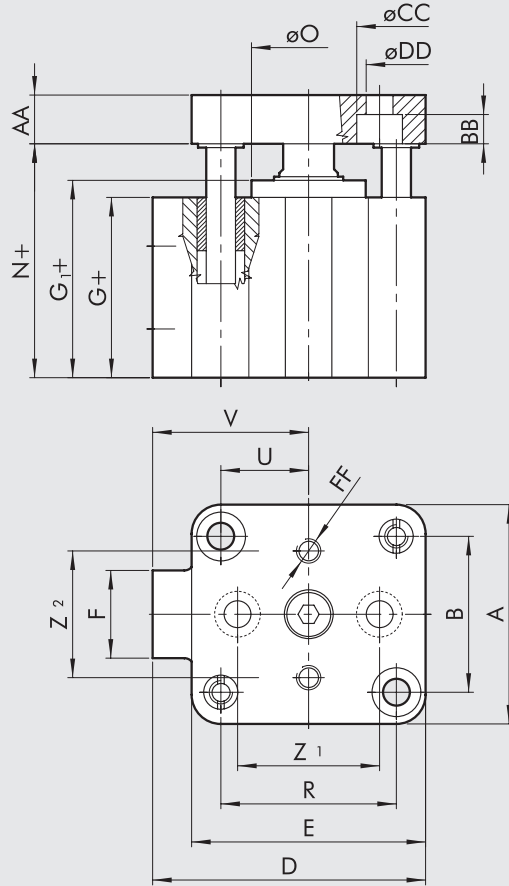

VERSIÓN DE DOBLE EFECTO (217)

Ø	A	B	øC	øC1	D	E	F	G	G1	H	H1	J	K	L	N	Z1	Z2	Q	R	øS	CH	U	V	AA	BB	øCC	øDD	øEE	FF	øGG	øO
16	28	20	8	7.5	33	28	11	33	-	6.7	10.5	3.7	6	3.7	37.5	20	15	M5	20	8	7	10	19	8	3.5	6	3.5	6	M3	4	-
20	32	22	10	9	37	32	11	32	-	6.5	10.5	4.6	7.5	4.6	37.6	22	18	M5	22	8	8	11	21	8	5	7.5	4.5	7.5	M4	6	-
25	37	26	10	9	47.5	39	18	33	36.5	8.5	8.5	4.6	7.5	4.6	42.5	22	22	G1/8	28	15	8	14	28	8	5	7.5	4.5	8	M4	6	20
32	45	32	12	11	56	48	18	37	40.8	10	10	5.5	10	5.7	48.3	26	26	G1/8	36	15	10	18	32	10	6	10	5.5	10	M5	8	25
40	54.5	40	12	11	62.7	54.5	18	39.5	44.7	10	10	5.5	10	5.7	53.2	34	34	G1/8	40	15	10	20	35.5	10	6	10	5.5	10	M5	8	30
50	66	50	16	15	73	66	18	39.5	46.2	11	11	6.6	11	6.8	54.3	43	43	G1/8	50	15	13	25	40	12	7	11	6.5	11	M6	10	35
63	80	62	16	15	88	80	23	42	48.7	12	12	9	15	9	57.7	55	55	G1/8	62	15	13	31	48	12	9	14	9	15	M6	10	35
80	100	82	20	19	110	100	26	57	67.2	14	14	9	15	9	75.2	70	70	G1/4	82	19	17	41	60	14	9	14	9	15	M8	12	44
100	124	103	25	24	134	124	26	64	74.7	15	15	11	18	11	84.3	94	94	G1/4	103	19	22	51.5	72	17	9	14	9	18	M8	12	56

VERSIÓN PASANTE DE SIMPLE EFECTO (215)

Ø	Eje	A	B	øC	øC1	D	E	F	G	G1	H	H1	J	K	L	M	N	øO	P	Q	R	øS	CH	T	U	V
16	5-25	28	20	8	7.5	33	28	11	33	-	6.7	10.5	3.7	6	3.7	10	37.5	-	M5	M5	20	8	7	2	10	19
20	5-25	32	22	10	9	37	32	11	32	-	6.5	10.5	4.6	7.5	4.6	10	37.6	-	M5	M5	22	8	8	2	11	21
25	5-25	37	26	10	9	47.5	39	18	33	36.5	8.5	8.5	4.6	7.5	4.6	10	42.5	20	M5	G1/8	28	15	8	2	14	28
32	5-25	45	32	12	11	56	48	18	37	40.8	10	10	5.5	10	5.7	15	48.3	25	M6	G1/8	36	15	10	2.5	18	32
	> 25-50								45	48.8							56.3									
40	5-25	54.5	40	12	11	62.7	54.5	18	39.5	44.7	10	10	5.5	10	5.7	15	53.2	30	M6	G1/8	40	15	10	2.5	20	35.5
	> 25-50								47.5	52.7							61.2									
50	5-25	66	50	16	15	73	66	18	39.5	46.2	11	11	6.6	11	6.8	18	54.3	35	M8	G1/8	50	15	13	3.5	25	40
	> 25-50								47.5	54.2							62.3									
63	5-25	80	62	16	15	88	80	23	42	48.7	12	12	9	15	9	18	57.7	35	M8	G1/8	62	15	13	3.5	31	48
	> 25-50								50	56.7							65.7									



**DIMENSIONES VERSIÓN VÁSTAGO PASANTE**

+ = AÑADIR LA CARRERA  
 ++ = AÑADIR 2 VECES LA CARRERA

VÁSTAGO PASANTE HUECO

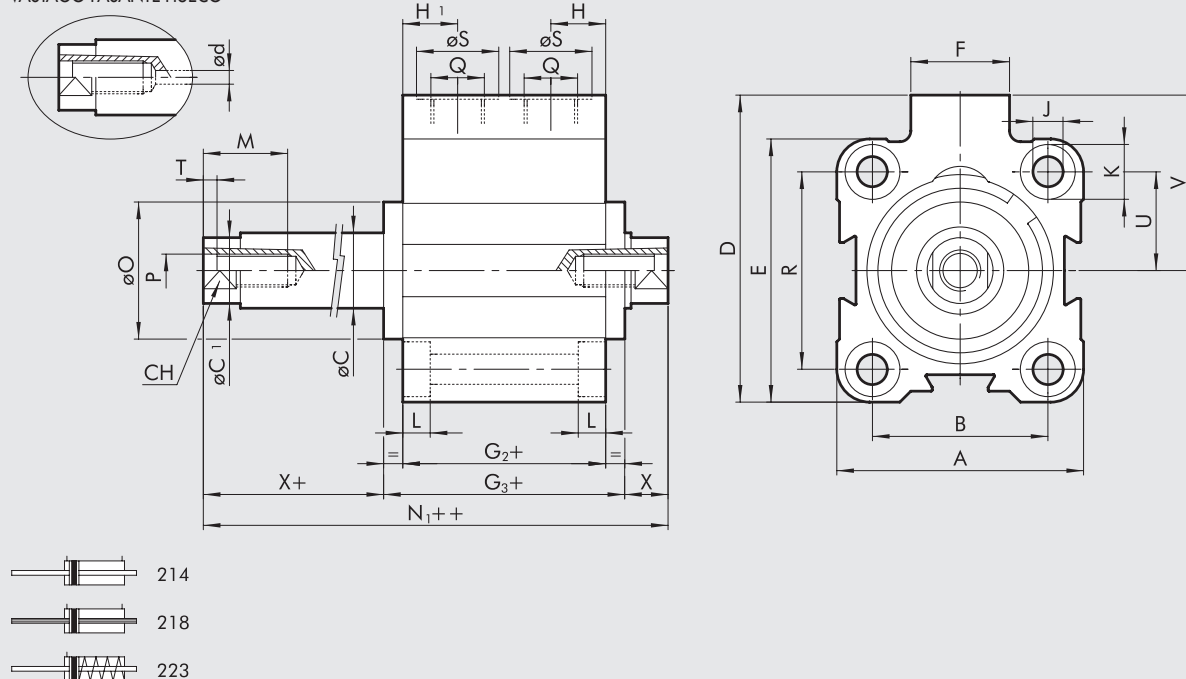

ACTUADORES

CILINDRO DE CARRERA CORTA SERIE SSCY

**DIMENSIONES VERSIÓN DOBLE EFECTO VÁSTAGO PASANTE Y VÁSTAGO PASANTE HUECO**

Ø	A	B	øC	øC <sub>1</sub>	D	ød**	E	F	G <sub>2</sub>	G <sub>3</sub>	H	H <sub>1</sub>	J	K	L	M	N <sub>1</sub>	øO	P	Q	R	øS	CH	T	U	V	X*
12	23.5	13	6	5.5	28	-	26	11	36.7	-	10.5	10.5	3.7	6	3.7	7	47.7	-	M3	M5	-	8	5	2	9.5	16.5	5.5
16	28	20	8	7.5	33	-	28	11	36.8	-	10.5	10.5	3.7	6	3.7	10	45.8	-	M5	M5	20	8	7	2	10	19	4.5
20	32	22	10	9	37	1.5	32	11	36	-	10.5	10.5	4.6	7.5	4.6	10	47.2	-	M5	M5	22	8	8	2	11	21	5.6
25	37	26	10	9	47.5	1.5	39	18	35.7	42.7	8.5	8.5	4.6	7.5	4.6	10	54.7	20	M5	G1/8	28	15	8	2	14	28	6
32	45	32	12	11	56	2.5	48	18	37	44.5	10	10	5.5	10	5.7	15	59.5	25	M6	G1/8	36	15	10	2.5	18	32	7.5
40	54.5	40	12	11	62.7	2.5	54.5	18	39.5	49.9	10	10	5.5	10	5.7	15	66.9	30	M6	G1/8	40	15	10	2.5	20	35.5	8.5
50	66	50	16	15	73	2.5	66	18	39.5	52.9	11	11	6.6	11	6.8	18	69.1	35	M8	G1/8	50	15	13	3.5	25	40	8.1
63	80	62	16	15	88	4	80	23	42	55.4	12	12	9	15	9	18	73.4	35	M8	G1/8	62	15	13	3.5	31	48	9
80	100	82	20	19	110	5	100	26	57	77.4	14	14	9	15	9	18	93.4	44	M10	G1/4	82	19	17	4	41	60	8
100	124	103	25	24	134	6	124	26	64	85.4	15	15	11	18	11	20	104.6	56	M12	G1/4	103	19	22	5	51.5	72	9.6

\* para Ø 12, 16, 20: (N<sub>1</sub>++) = (G<sub>2</sub>+) + (X) + (X+)

\*\* columna solamente para vástago pasante hueco

**DIMENSIONES VERSIÓN SIMPLE EFECTO VÁSTAGO PASANTE**

Ø	carrera	A	B	øC	øC <sub>1</sub>	D	E	F	G <sub>2</sub>	G <sub>3</sub>	H	H <sub>1</sub>	J	K	L	M	N <sub>1</sub>	øO	P	Q	R	øS	CH	T	U	V	X*
12	5÷25	23.5	13	6	5.5	28	26	11	36.7	-	10.5	10.5	3.7	6	3.7	7	47.7	-	M3	M5	-	8	5	2	9.5	16.5	5.5
16	5÷25	28	20	8	7.5	33	28	11	36.8	-	10.5	10.5	3.7	6	3.7	10	45.8	-	M5	M5	20	8	7	2	10	19	4.5
20	5÷25	32	22	10	9	37	32	11	36	-	10.5	10.5	4.6	7.5	4.6	10	47.2	-	M5	M5	22	8	8	2	11	21	5.6
25	5÷25	37	26	10	9	47.5	39	18	35.7	42.7	8.5	8.5	4.6	7.5	4.6	10	57.7	20	M5	G1/8	28	15	8	2	14	28	6
32	5÷25	45	32	12	11	56	48	18	37	44.5	10	10	5.5	10	5.7	15	59.5	25	M6	G1/8	36	15	10	2.5	18	32	7.5
	> 25÷50								45	52.5							67.5										7.5
40	5÷25	54.5	40	12	11	62.7	54.5	18	39.5	49.9	10	10	5.5	10	5.7	15	66.9	30	M6	G1/8	40	15	10	2.5	20	35.5	8.5
	> 25÷50								47.5	57.9							74.9										8.5
50	5÷25	66	50	16	15	73	66	18	39.5	52.9	11	11	6.6	11	6.8	18	69.1	35	M8	G1/8	50	15	13	3.5	25	40	8.1
	> 25÷50								47.5	60.9							77.1										8.1
63	5÷25	80	62	16	15	88	80	23	42	55.4	12	12	9	15	9	18	73.4	35	M8	G1/8	62	15	13	3.5	31	48	9
	> 25÷50								50	63.4							81.4										9

\* para Ø 12, 16, 20: (N<sub>1</sub>++) = (G<sub>2</sub>+) + (X) + (X+)

DIMENSIONES VERSIÓN 222 (CHARNELA HEMBRA MOD. B) - VERSIÓN 221 (CHARNELA MACHO MOD. BA)

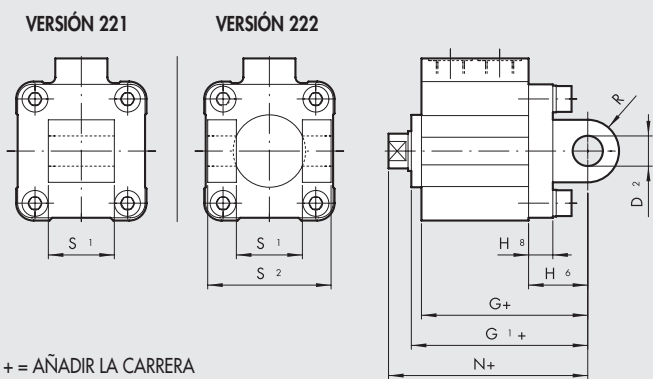

+ = AÑADIR LA CARRERA

Ø	carrera	D <sub>2</sub>	G	G <sub>1</sub>	H <sub>6</sub>	H <sub>8</sub>	N	R	S <sub>1</sub>	S <sub>2</sub>
32	5 ÷ 70	10	59	62.8	22	10	70.3	11	26	45
40	5 ÷ 70	12	64.5	69.7	25	10	78.2	13	28	52
50	5 ÷ 110	12	66.5	73.2	27	12	80.2	13	32	60
63	5 ÷ 110	16	74	80.7	32	12	89.7	17	40	70

Nota: para todas las otras dimensiones ver la versión estándar

CLAVES DE CODIFICACIÓN

CIL	2 1 2 TIPOLOGIA	0	4 0 DIÁMETROS	0 0 1 0 CARRERA	C MATERIAL	P JUNTAS
■	208 Simple efecto vástago retraído no-magnético	0 Estándar	12	Para carreras maximas ver en datos tecnicos	C Vástago cromado C45, pistón de tecnopolimero Ø 12 ÷ 63 mm	P Juntas en poliuretano
■	209 Simple efecto vástago extendido no-magnético	S No-magnético	16		A Vástago C45 cromada, pistón de aluminio (estándar Ø 80 ÷ 100 mm)	N Juntas en NBR
■	210 Simple efecto vástago retraído	▲ G No stick-slip	20		X Vástago inoxidable y pistón en tecnopolimero Ø 12 ÷ 63 mm	● V Juntas en FKM/FPM
■	211 Simple efecto vástago extendido		25		Z Vástago inoxidable y pistón en aluminio (estándar Ø 80 ÷ 100 mm)	● B Baja temperatura
	212 Doble efecto magnético		32			
	213 Doble efecto no-magnético		40			
	214 Doble efecto vástago pasante		50			
■	215 Simple efecto retraído antirotación		63			
	217 Doble efecto antirotación		80			
▼	218 Doble efecto vástago pasante hueco		◆ 100			
	221 Charnela oscilante macho (sólo hasta Ø 63)					
	222 Charnela oscilante hembra (sólo hasta Ø 63)					
■	223 Simple efecto vástago pasante					

- ◆ Cuando la 4ª cifra está ocupada para una letra Ø 100 = A1
- Disponible para Ø 63
- ▼ Disponible de Ø 20

- Disponible sólo para versión no-magnético (S) Disponible sólo para versión (A o Z)
- ▲ Para evitar saltos a velocidades inferiores a 0.2 m/s. Utilizar solo aire no lubricado

ACCESORIOS

DIMENSIONES: NIPLO MACHO PARA VÁSTAGO

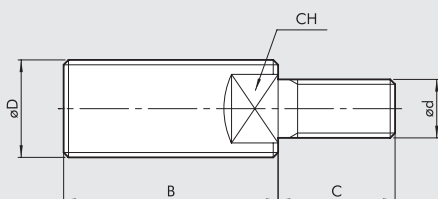

Código	Ø	Ø D	Ø d	B	C	CH	Peso [g]
219001200	12	M6	M3	16	6	4	3
219001600	16	M8	M5	20	9	6	8
219001600	20	M8	M5	20	9	6	8
219002500	25	M10x1.25	M5	22	9	7	12
219003200	32	M10x1.25	M6	22	12	7	14
219004000	40	M12x1.25	M6	24	12	10	14
219005000	50	M16x1.5	M8	32	15	13	20
219005000	63	M16x1.5	M8	32	15	13	20
219008000	80	M20x1.5	M10	40	15	17	96
219010000	100	M20x1.5	M12	40	18	17	102



## SENSORES MAGNÉTICOS

### SENSOR SERIE DCB

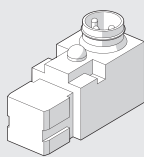

Para códigos y datos técnicos generales, véase el capítulo A6.

### SENSOR INSERTABLE

#### SENSOR TIPO CUADRADO

Última generación, fijación segura

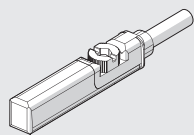

#### SENSOR TIPO OVALADO

Tradicional

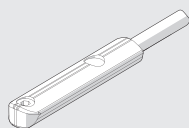

Para códigos y datos técnicos generales, véase el capítulo A6.

### ADAPTADOR PARA SENSORES INSERTABLES TIPO CUADRADO Y OVALADO

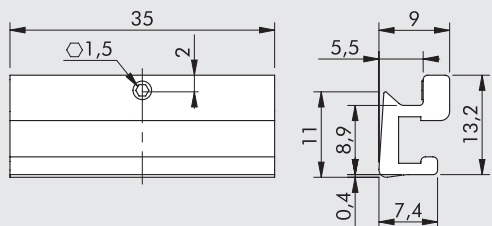

Código	Ø	Descripción
W0950001101	Ø 12 ÷ 100	Adaptador de sensor para cilindros SSC

#### DIAGRAMA DE MONTAJE

- ① Cilindro SSCY
- ② Adaptador de sensor para cilindros SSCY
- ③ Sensor retráctil "tipo ovalado"
- ④ Sensor retráctil "tipo cuadrado"
- ⑤ Tornillo prisionero para fijar el adaptador en el perfil

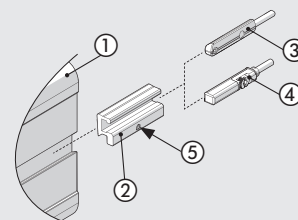

## RECAMBIOS PARA CILINDROS DE CARRERA CORTA

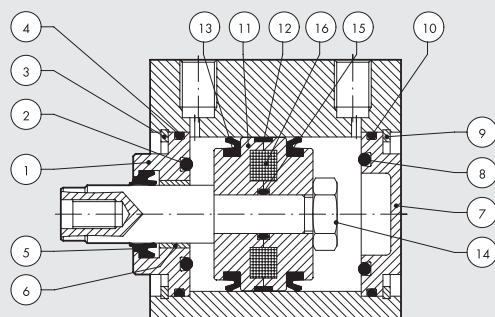

Código	Diámetros	Tipología	Partes
009 ... 0010	Ø 12÷100	Kit culata frontal completo poliuretano	1 2 3 4 5 6
009 ... 0011	Ø 12÷100	Kit culata frontal completo NBR	1 2 3 4 5 6
009 ... 0015	Ø 12÷100	Kit culata trasero completo NBR	7 8 9 10
009 ... 0021	Ø 12÷100	Kit pistón completo poliuretano	11 12 13 14 15
009 ... 0023	Ø 12÷100	Kit pistón completo NBR	11 12 13 14 15
009 ... 0005	Ø 12÷100	Kit juntas completo poliuretano	2 4 5 8 10 13 15
009 ... 0006	Ø 12÷100	Kit juntas completo NBR	2 4 5 8 10 13 15
009 ... 0007	Ø 12÷100	Kit completo juntas FKM/FPM (alta temperatura)	2 4 5 8 10 13 15
009 ... 2008	Ø 12 ÷ 63	Kit de junta de vástago de poliuretano	5
009 ... 2008	Ø 80 ÷ 100	Kit de junta de vástago de poliuretano + anillo seeger	5
009 ... 2009	Ø 12 ÷ 63	Kit de junta de vástago NBR	5
009 ... 2009	Ø 80 ÷ 100	Kit de junta de vástago NBR + anillo seeger	5
009 ... 2010	Ø 12 ÷ 63	Kit de junta de vástago de FKM/FPM	5
009 ... 2010	Ø 80 ÷ 100	Kit de junta de vástago de FKM/FPM + anillo seeger	5
009 ... 0031	Ø 12 ÷ 100	Kit culata frontal + trasero + pistón completo poliuretano	1 2 3 4 5 6 7 8 9 10 11 12 13 14 15
009 ... 0033	Ø 12 ÷ 100	Kit culata frontal + trasero + pistón completo NBR	1 2 3 4 5 6 7 8 9 10 11 12 13 14 15
009 ... 0001	Ø 12 ÷ 100	Magneto	16